

PRODUCT SPECIFICATION

PROPERTY / TEST METHOD	SPECIFICATION
Impedance at 500 kHz (11.8 sq inch [76 sq cm] sample)	35 ohms max
Stainless Steel (Skin Side) Adhesion (180° peel, grams per inch of width)	120 grams min ¹
Top Liner (Tie Side) Adhesion to Gel (grams per inch of width)	90 grams max
Gel Adhesion to Aluminum Foil (grams per inch of width)	230 grams min
Cytotoxicity	Pass
Primary Skin Irritation Test	Pass
Delayed Contact Hypersensitivity Test	Pass
Top Release Liner	2.5 mil, 0.064mm MDPE
Substrate	1 mil (0.025mm) Al / 3 mil (0.076mm) PET
Hydrogel Thickness	22 mils (+/- 5 mils)
Hydrogel pH	4.9 (+/- 0.5)
Roll Dimensions	Width - 5.6", Length - 400'
Shelf Life	12 months ²
Core Size	6"

¹ Stainless Steel is not a true measure of skin adhesion. AG902-100/142 has good "quick grab" and excellent restick.

² Shelf life is for roll goods prior to conversion. Shelf life for finished goods is the responsibility of the converter.

NOTE: Converter assumes responsibility for material compatibility. However, should assistance be required, our professional chemical and engineering staff is available to support your technical needs.

PACKAGING SPECIFICATION

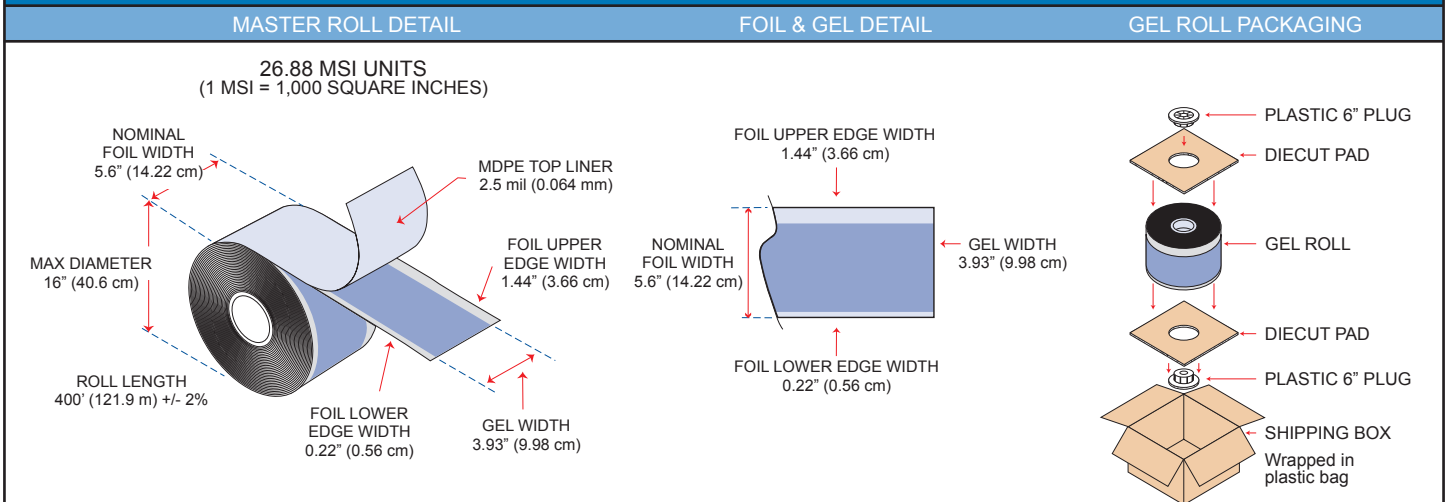

BOX SIZE AND WEIGHT: 17" x 17" x 12" APPROX. 68 lbs. (31 kg)

SHIPPING BY PALLET: 16 boxes (APPROX. 54"H x 45"W x 45"D) APPROX. 1,200 lbs. (544 kg)

PROPER STORAGE CONDITIONS OF PACKAGED ROLLS

- Short Term (less than one month) Temperature: 32° - 104°F (0° - 40°C) Relative Humidity 35 - 50%
- Long Term and Optimal Temperature: 41° - 80.6°F (5° - 27°C) Relative Humidity 35 - 50%

IMPORTANT: STORE RIGHT SIDE UP

TOLL FREE: +1 (877) 728-7315 • FAX: +1 (760) 728-3429 • INTERNATIONAL: +1 (760) 728-3480

E-MAIL: info@amgel.com • HEADQUARTERS: Fallbrook, CA 92028, USA • www.amgel.com