

PRODUCT SPECIFICATION

| PROPERTY / TEST METHOD | SPECIFICATION |
|--|--|
| Stainless Steel (Skin Side) Adhesion (180° peel, grams per inch of width) | 250 grams min ¹ |
| Top Liner (Tie Side) Adhesion to Gel (grams per inch of width) | 120 grams max |
| Bottom Liner (Skin Side) Adhesion to Gel (grams per inch of width) | 140 grams max |
| Cytotoxicity | Pass |
| Primary Skin Irritation Test | Pass |
| Delayed Contact Hypersensitivity Test | Pass |
| Top Release Liner | 2.5 mil, 0.064mm MDPE |
| Bottom Release Liner | 5 mil, 0.127mm PET |
| Hydrogel Thickness | 44 mils (+/- 5 mils) |
| Hydrogel pH | 4.3 (+/- 0.5) |
| Roll Dimensions | Width - 8.75" usable gel, Length - 250' |
| Shelf Life | Slit - 6 months ² , Non-slit - 12 Months ² |
| Core Size | Slit - 3", Non-slit - 6" |

¹ Stainless Steel is not a true measure of skin adhesion. AG501 has good "quick grab" and excellent restick.

² Shelf life is for roll goods prior to conversion. Shelf life for finished goods is the responsibility of the converter.

NOTE: Converter assumes responsibility for material compatibility. However, should assistance be required, our professional chemical and engineering staff is available to support your technical needs.

PACKAGING SPECIFICATION

MASTER ROLL DETAIL

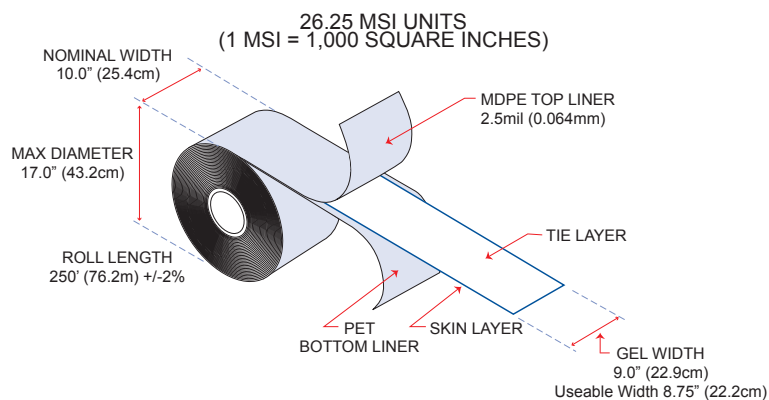

GEL ROLL PACKAGING

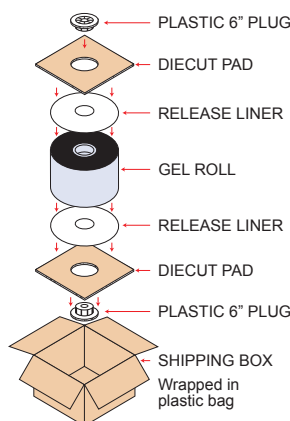

SLIT GEL ROLL PACKAGING

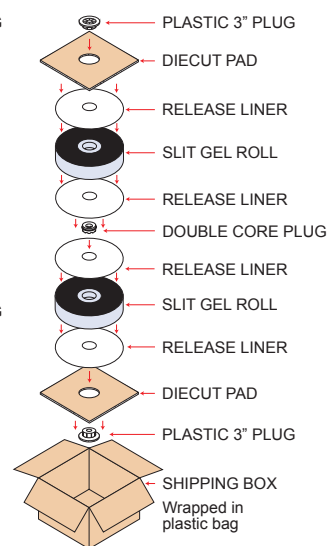

BOX SIZE AND WEIGHT: 17" x 17" x 12" APPROX. 69 lbs. (31.3 kg)

SHIPPING BY PALLET: 16 boxes (APPROX. 54"H x 45"W x 45"D) APPROX. 1,104 lbs. (500.8 kg)

PROPER STORAGE CONDITIONS OF PACKAGED ROLLS

- Short Term (less than one month) Temperature: 32° - 104°F (0° - 40°C) Relative Humidity 35 - 50%
- Long Term and Optimal Temperature: 41° - 80.6°F (5° - 27°C) Relative Humidity 35 - 50%

TOLL FREE: +1 (877) 728-7315 • FAX: +1 (760) 728-3429 • INTERNATIONAL: +1 (760) 728-3480

E-MAIL: info@amgel.com • HEADQUARTERS: Fallbrook, CA 92028, USA • www.amgel.com